



5. Tank-to-tank Connection

If you wish, you can connect two Alana Water Butts together at the drain down point near the base at the side of the tank. A 3P 3/4" Tank to Tank Connection Kit is ideal for this. Measure the distance between the threaded ports before ordering the required length of hose in the Connection Kit from your water butt supplier.



Instructions

To fill the Alana, we recommend using the 3P Filter Collector with rubber grommets for the 32mm connection hose.

Where the water butt cannot be located within 30 cm of the downpipe, longer Long Link Kits are available from your dealer.



The 3P Filter Collector is available in four colours to match your downpipe; black, grey, brown and white.

The Alana is delivered with an accessory kit which includes a chrome tap, hole-saw set, 30cm length of hose, rubber grommets, wall bracket, and screws.

If in any doubt during installation, please consult a professional tradesperson or the supplier of your filter or diverter.



1. Setting up

Site the rain tank on a firm, level surface adjacent to a downpipe.

Read through these instructions and the 3P Filter Collector Instructions or other rain diverter instructions fully before proceeding.

This is a sealed tank so you cannot use a backnut to make a connection.

If in any doubt during installation, please consult a professional tradesperson or the supplier of your filter or diverter.

Note about Diverters

For the correct hole size, refer to your diverter's instructions. You may be able to use the 3P hole saw. Check before using. The connector parts supplied with the Alana are intended for use with a 3P Filter Collector.

2. Fitting the 3P Filter Collector

Locate the connection area

There are two connection areas - one on either side of the water butt. The Diverter Hose must be connected to either of these points. Drilling in other locations will result in leaks due to the surface design of the Alana.

Hole Cutter Selection - 58 mm

To fill the water butt with the recommended 3P Filter Collector select the 58mm hole saw from the set provided.

Drilling

Offer the drill to the marked point and proceed to drill the hole. If you are fitting a brand of diverter other than 3P Filter Collector, check first that you are drilling the correct hole size for the diverter you are using.

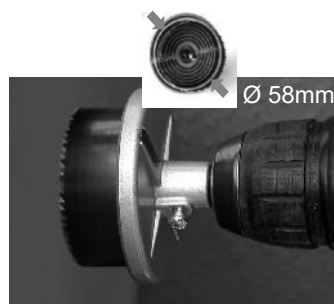

2. Continued

Connecting the Hose to the Water Butt

Push fit the 50mm AND 32mm grommet into the drilled hole and then push the 32mm hose into the grommet to make a water tight seal. It will need lubrication to ease the hose through the grommet.



3. Connecting the Tap

Screw the 3/4" brass tap provided in the Kit into the 3/4" BSP connection thread. If necessary, use PTFE tape when installing the tap to create a more watertight seal and to allow the tap to sit in the correct position.

4. Fixing the Wall Bracket

Fill the tank with water before attaching the wall bracket to avoid deflection. The bracket is optional.

Winter Care Precautions

To prevent any damage from being caused, we recommend the Alana is drained completely and disconnected from the rainwater inlet during prolonged freezing weather conditions.



Planting If required, in areas that experience a lot of rain, you may wish to drill some small drainage holes in the base of the planter section (on the small dome) and cover the holes with cloth or mesh to stop soil falling through. This will allow the planter section to be drained by opening the tap.